

# TIPV *Twin Isolation Plug Valve*

Double Block & Bleed Plug Valve



Serck Audco Valves

# Twin Isolation Plug Valve

## Contents

Introduction	pages 3 & 4
Typical Installations	pages 5 & 6
Range	page 6
Main Features	page 7
Figure Numbering / Standards	page 8
Design Features	pages 9 & 10
Pressure Testing	page 11
Valve Data	pages 12 - 17
Materials	pages 18 & 19
Sealants	pages 20 - 23

# Introduction - TIPV

## Twin Isolation Plug Valve

Based on Serck Audco SUPER-H pressure balanced taper plug technology, Twin Isolation Plug Valve offers true bubble tight double block and bleed, within a single valve body.

The oil and gas industry is no longer satisfied with the shut-off provided by conventional double block and bleed ball, gate or plug valves. True double block has become a prime requirement as safety standards are raised throughout the industry, especially where it is necessary for an operator to work downstream (or upstream) of the valve.

A further advantage of true double isolation (where the first plug gives complete isolation), is that the bleed point can be used to verify that no contamination has occurred when more than one type of line medium has passed down the pipeline.

The Serck Audco Super-H plug valve is widely acknowledged in the oil and gas industry for its superior shut-off at high differential pressures together with excellent reliability and durability. This same design is used in the Serck Audco Twin Isolation Plug Valve.

## What are the benefits?

- No pipework modification - total interchangeability with existing valves.
- Choice of bleed connection options.
- Same range as single valve - including hard facing.
- Meets the same industry and fire-test standards as a single valve.
- Low life cycle cost - less than two single valves.
- Assured sealing on both sides of the valve.
- Reduced leak paths - eliminates inter-valve pipework on double block and bleed configurations.
- Compact, lightweight alternative to gate valves and ball valves in series.

### Single Plug - Single Isolation

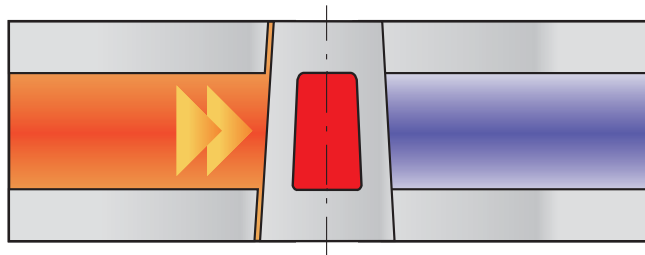

### Double Plug - Double Isolation

Independently operated plugs mean maximum downstream isolation safety.

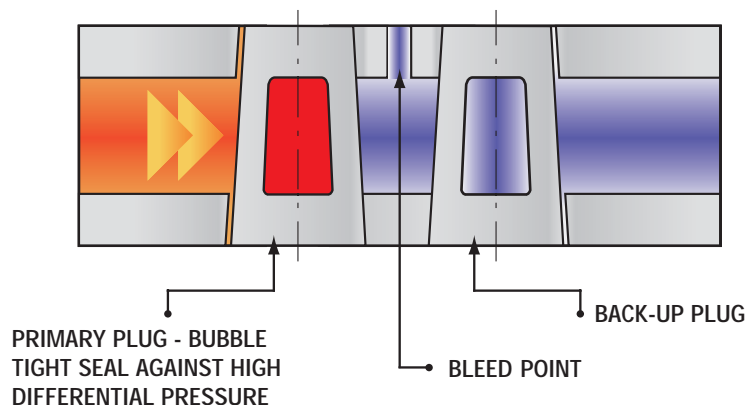

# Proven plug valve integrity

Setting new standards for  
double block & bleed

True double isolation within a  
single valve body

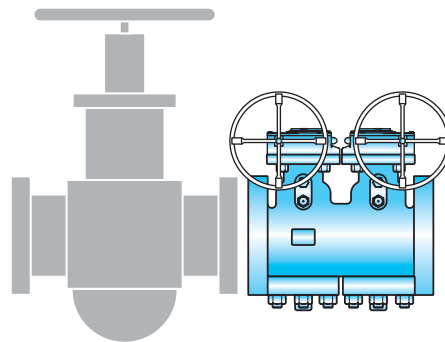

## COMPARED WITH GATE VALVES

- Same face-to-face but smaller overall.
- Compact design means less weight.

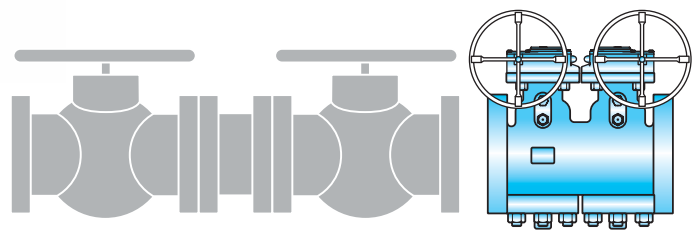

## COMPARED WITH BALL VALVES

- One TIPV replaces two ball valves.
- Less interconnecting pipework means fewer leak paths.
- Weight saving.
- Cost saving.

# Typical Installations

## Gas Transportation - Gas Compression Station



CONFIGURATION USING BALL VALVES

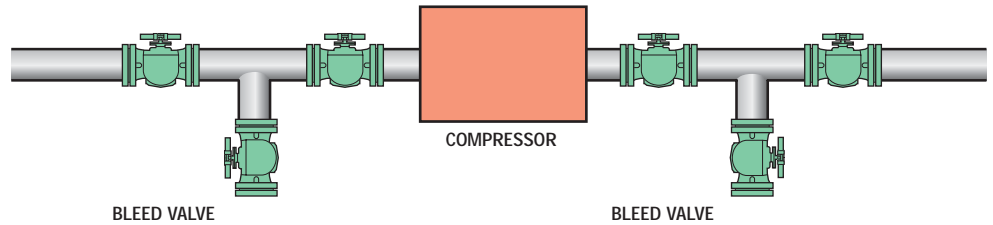

CONFIGURATION USING DOUBLE ISOLATION PLUG VALVES

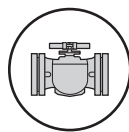
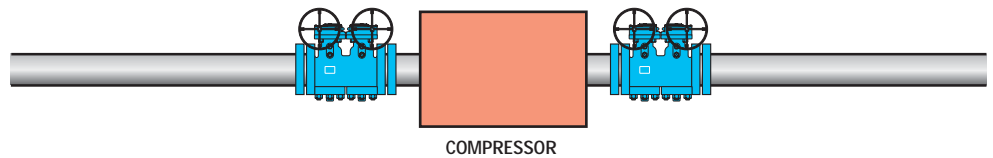

BALL VALVE

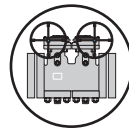

DOUBLE ISOLATING PLUG VALVE

## Oil & Gas Production - Well Heads Manifold

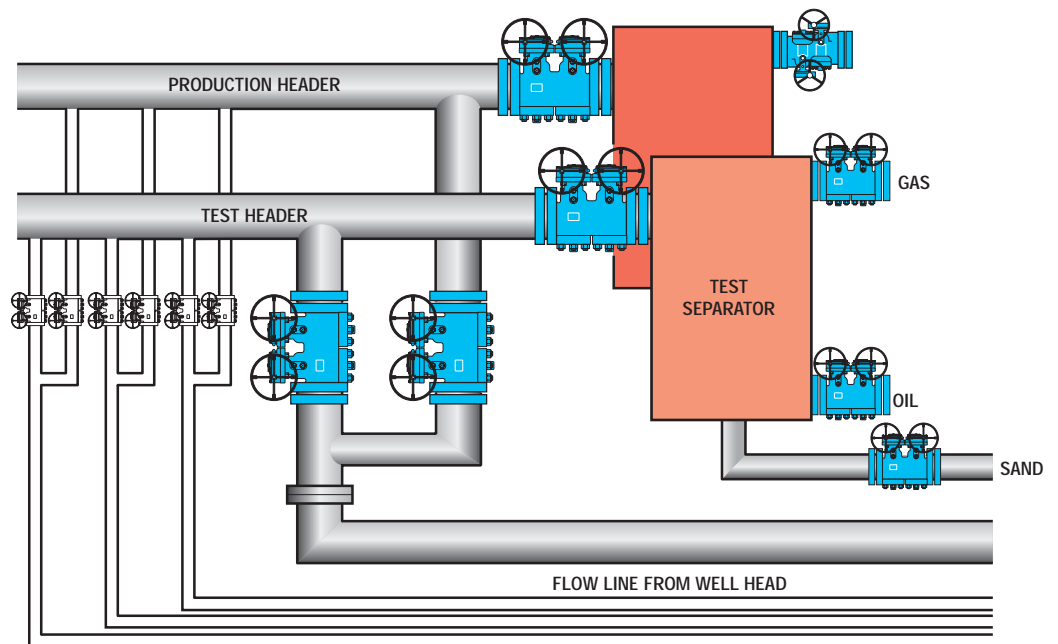

# Typical Installations



The valves illustrated are 6" class 2500 with hub ends, in carbon steel, manually operated. Criteria for selection: bubble tight isolation and compact design.



The valves illustrated are 12" class 2500 with hub ends. Criteria for selection: tight shut off, safety reliability and low maintenance.

# Range

inches	mm	Class					
		150	300	600	900	1500	2500
2	50	•	•	•	•	•	•
3	80	•	•	•	•	•	•
4	100	•	•	•	•	•	•
6	150	•	•	•	•	•	•
8	200	•	•	•	•	•	•
10	250	•	•	•	•	•	•
12	300	•	•	•	•	•	•
14	350	•	•	•	•	•	•
16	400	•	•	•	•	•	•
18	450	•	•	•	•	•	•
20	500	•	•	•	•	•	•
24	600	•	•	•	•	•	•

# Main Features

## Principles of Operation

Serck Audco Twin Isolation Plug Valves feature two separate Protected Pressure Balanced Taper Plugs and a centrally located bleed port, integral with the body. They are designed to give bubble tight shut off on both high and low pressure applications. This is a robust, In-Line Maintainable valve with low maintenance requirements. The valve body is a rigid single piece casting. The blow out proof valve stems are internally assembled and retained in the body. The separate plugs are retained in the body by a bolted cover. The design incorporates provision for external maintenance of the individual stem packings. The individual plug position in the valve seats allows for valve sealant to be injected onto the valve seats, which are the tapered contact surfaces of the body and plugs.

## Plug Balancing

All TIPV valves are protected against the possibility of seizure due to taper locking. Taper locking is caused by an imbalance of forces acting on the plug due to line pressure finding its way into the lower (wider) part of the plug chamber. As shown by the arrows in Fig. 1, the resultant force tends to push the plug upwards, jamming it in its tapered bore. The plug can remain locked even when line pressure is subsequently reduced.

In an attempt to combat taper locking, conventional valves utilise the pressure of the plug sealant, acting on the upper face of the plug, to react against the upwards force. This reduces, but does not eliminate, the possibility of taper locking - and requires regular sealant injection to maintain valve freedom.

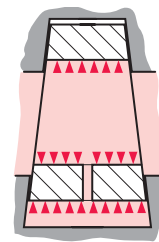

Fig. 1

## Pressure Balancing

Standard Super-H valves incorporate pressure balanced plugs, as shown in Fig. 2. The drilling and check valve in the top section of the plug allow the line pressure itself to counteract the upwards force, preventing any possibility of taper locking - without the need for frequent sealant injection.

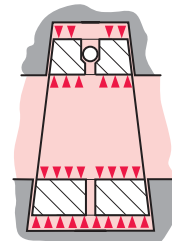

Fig. 2

## Protected Pressure Balancing<sup>(P)</sup>

Flowsolve Patent

For increased reliability in service and where there is a possibility of particles in the media we incorporate Protected Pressure Balance as standard on the TIPV (Fig 3). This design ensures that the balancing holes are not exposed to the line media in the plug port, providing added security compared with normal pressure balancing.

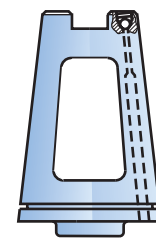

Fig. 3

## Super-LoMu Treatment

All Carbon Steel taper plug valves have plugs with Super LoMu treatment. In this unique process, low friction PTFE is incorporated in the surface structure of the valve plug metal. This gives easier operation and enhanced resistance to taper lock over thousands of operations or many years of service.

## Sealant Type

All valves described in this data book are filled with 733 sealant. If you require a sealant different from normal, please state this at the time of ordering so that the valve can be assembled with the correct sealant. In those cases where no previous experience exists regarding the suitability of the normal sealant for the line fluid on which the valve is to be used, please provide full service details so that we may ensure that the correct type of sealant is used in the assembly of the valve.

# Figure Numbering

The opposite illustrates a typical figure number. If a fuller explanation is required please request Standards Sheet 0028-4001.

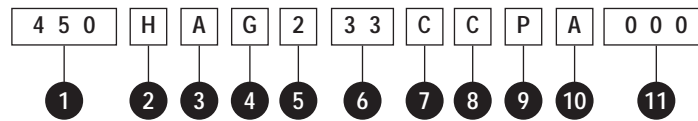

## Key

- |  |   |   |
|--|---|---|
| <p><b>1</b> Size<br/>eg. 450 mm OR 18"</p> <p><b>2</b> Valve Type<br/>eg. Super H</p> <p><b>3</b> TIPV Double Isolation<br/>(Twin Plug)</p> <p><b>4</b> Operation<br/>G - Geared<br/>N - Bare Stem<br/>W - Wrench</p> <p><b>5</b> Pressure Rating<br/>2 - ASME 150<br/>3 - ASME 300<br/>6 - ASME 600<br/>9 - ASME 900<br/>A - ASME 1500<br/>B - ASME 2500<br/>C - API 2000<br/>D - API 3000<br/>E - API 5000</p> | <p><b>6</b> End Connections<br/>2 - Screwed BSP Taper<br/>3 - Flanged RF<br/>4 - Screwed API 5L<br/>5 - Flanged RTJ<br/>6 - Butt Weld End<br/>9 - Socket Weld End</p> <p><b>7</b> Body Material<br/>C - Steel WCB<br/>B - Alloy Steel (API6A)<br/>M - LCC/LF2</p> <p><b>8</b> Plug Material<br/>C - Case Hardened Carbon Steel<br/>J - Electroless Nickel Coated Carbon Steel (0.003" for NACE)<br/>M - Electroless Nickel Coated Manganese Steel (LCC)<br/>T - 17-4 PH Stainless Steel</p> | <p><b>9</b> Options<br/>V - NACE MR0175 'Wetted Parts' and Cover Bolts<br/>P - NACE MR0175 'Wetted Parts'<br/>S - Special Customer requirements</p> <p><b>10</b> Sealant Grade<br/>A - 733<br/>B - 733LT<br/>C - 733X<br/>D - 731<br/>S - Special</p> <p><b>11</b> Supplementary Variations</p> |
|--|---|---|

# Standards

The requirements for steel valves for refinery use are defined in API 599, BS 5353 is based on API 599 and plug valves to these two standards are interchangeable in all respects if the appropriate pattern is selected and steel plugs are used. Steel pipeline valves are covered by API 6D for which there is no direct British equivalent. However BS 5353 is a more stringent specification, so that valves complying with it will also meet API 6D. API 6D permits iron plugs: BS 5353 permits iron plugs only by agreement between purchaser and supplier. Therefore, it is British practice to manufacture the valves to BS 5353 except for the substitution of iron plugs. Double Isolation Plug Valves meet the requirements of BS 5353, API 599, API 6D and ANSI B16.34. Valves made in materials to meet API 6A are also available.

BS 2080	Face-to-face, centre-to-face, end-to-end, and centre-to-end dimensions of flanged and butt welding end steel valves for the petroleum, petrochemical and allied industries.
BS EN 12266-1	Testing of valves. Part 1 Specification for production pressure testing requirements.
BS 6755 Pt 2	Testing of valves. Part 2 Specification for fire type-testing requirements.
BS 5353	Specification for steel plug valves.
ANSI B16.10	Face-to-face and end-to-end dimensions of ferrous valves.
ANSI B16.34	Valves - flanged and butt welding end.
API 6A	Specification for wellhead equipment.
API 6D	Specification for pipeline valves.
API 599	Steel plug valves flanged or butt welding ends.
API 6FA	Fire test for valves.
NACE MR0175	Sulphide stress cracking resistant metallic material for oilfield equipment.
ISO 9001	Quality Assurance approval standard.

# TIPV Design Features

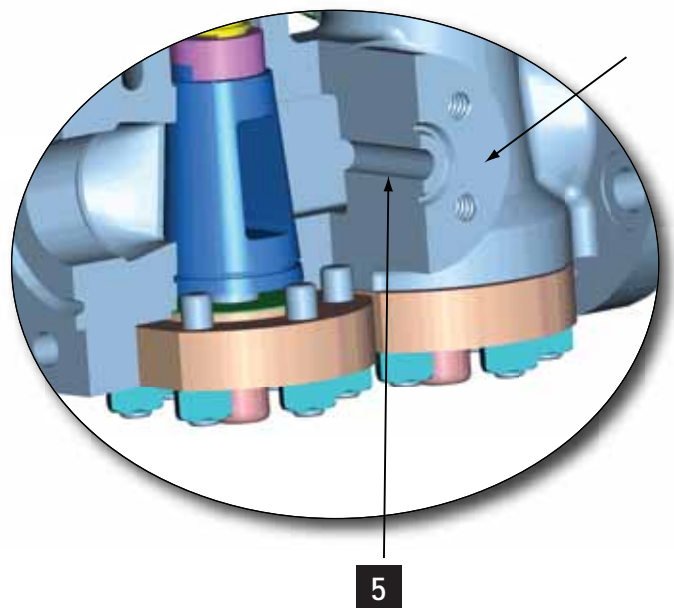
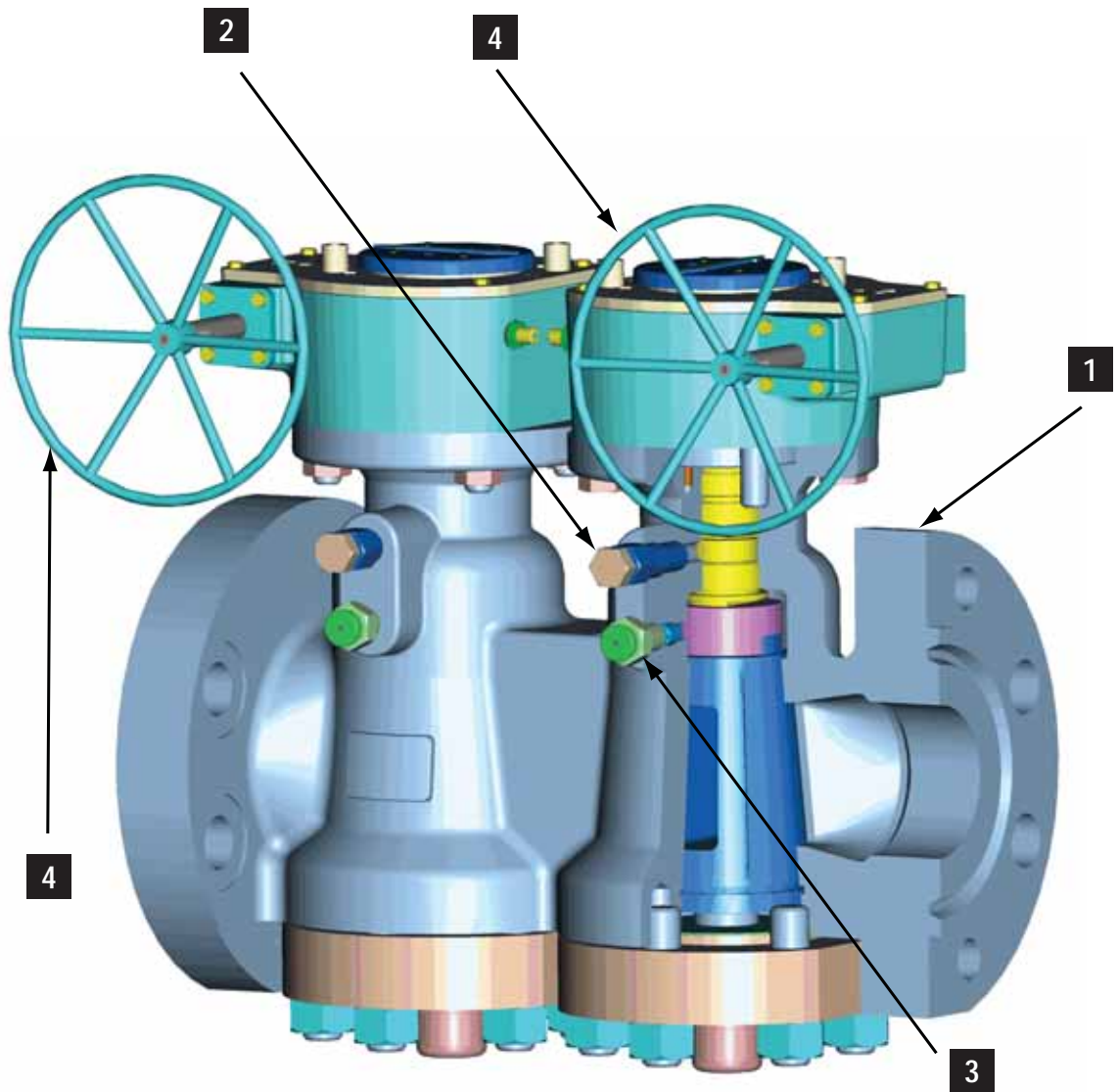

- 1** Same face-to-face as one valve.
- 2** In-line emergency stem sealing.
- 3** In-line sealant injection point.
- 4** Choice of mounting positions for actuators and handwheels.
- 5** Bleed port.
- 6** Bleed valve flange interface.

# Design Features

## 2" - 24" Class 150 - 2500

### Main Features

(Components are shown for one plug assembly only.

The adjacent plug components are identical.)

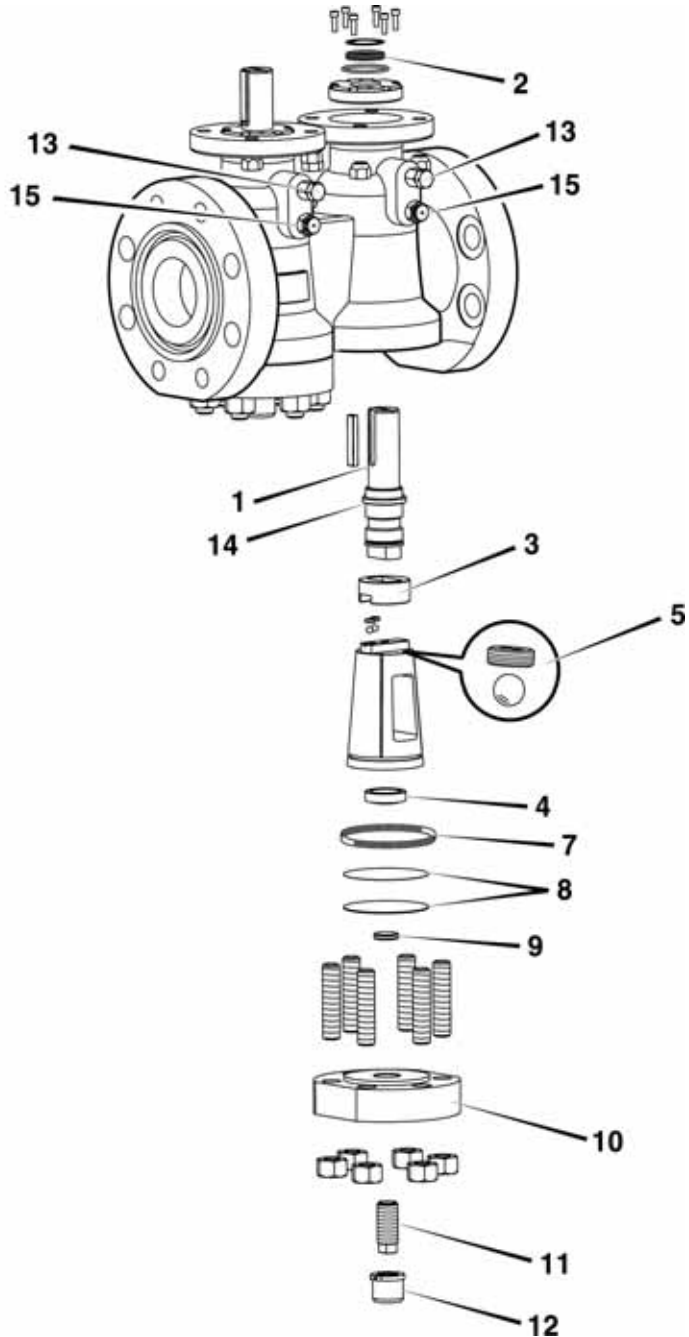
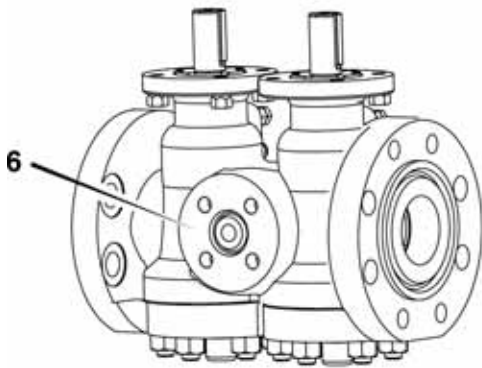

- 1 Key Drive Blow Out Proof Stem: Super LoMu treated.
- 2 Weather Seal-Quadring.
- 3 Equaliser Ring: for low torque and bubble tight sealing.
- 4 Plug: Metal-to-metal seating, Super LoMu treated.
- 5 Pressure Balance Ball Valve.
- 6 Bleed Port: integral with body.
- 7 Bearing Pad.
- 8 Diaphragms.
- 9 Thrust Pad.
- 10 Bolted Cover.
- 11 Plug Loading Screw.
- 12 Protective Cap.
- 13 Stem Packing Compound Injector: renews sealing to atmosphere.
- 14 Graphite 'Fire Safe' Stem Seal.
- 15 Seat Sealant Injector: renews sealing to downstream.
- 16 Spiral Wound Gasket (if fitted).

# Pressure Testing

## Test Pressures

VALVE RATING	Maximum C.W.P.		BODY TEST (minimum)		SEAT TEST (minimum)	
	bar	lbf/in <sup>2</sup>	bar	lbf/in <sup>2</sup>	bar	lbf/in <sup>2</sup>
CLASS 150 PN 20	19.5	285	29.5	427.5	21.5	313.4
CLASS 300 PN 50	51	740	76.5	1110	56	814
CLASS 600 PN 100	102	1480	153.2	2220	112	1628
CLASS 900 PN 150	153	2220	230	3330	168	2442
CLASS 1500 PN 250	256	3705	383	5558	281	4076
CLASS 2500 PN 420	425	6170	638	9255	468	6787
API 2000	138	2000	276	4000	138	2000
API 3000	207	3000	414	6000	207	3000
API 5000	345	5000	690	10000	345	5000

API pressures are taken from API 6A, all other pressures are taken from ANSI 16.34. The test pressures from ANSI 16.34 are those relevant to Carbon Steel ASTM A 216 Gr WCB.

There may not be exact equivalence between pressure in bar and in lbf/in<sup>2</sup> due to rounding (1 bar = 10<sup>5</sup> Pa).

Each relevant standard defines the minimum length of time for which each test pressure is to be maintained and also the testing operations sequence.

Duration of hydrostatic tests in minutes (minimum)					
VALVE SIZE		BS EN 12266-1		API 6D	
		SHELL TEST	SEAT TEST	SHELL TEST	SEAT TEST*
40 mm	≤ 1½"	¼	¼	not applicable	
50 mm	2"	¼	¼	2	2
65-100 mm	2½-4"	1	½	2	2
150 mm and 200 mm	6" and 8"	1	½	5	5
250 mm	10"	3	1	5	5
300 mm and 450 mm	12-18"	3	1	15	5
500 mm	≤ 20"	3	2	30	5

\* These durations will be adhered to unless a different specification is required against a particular order.

Hydrostatic tests of long duration require that the valve be given special attention to facilitate pipeline testing. Plug sealant should be injected before the start of the test, after the test has finished and at any time during the test that there is a sign of leakage.

# TIPV - Class 150

Dimensions in these tables are for standard trim valves and are to the nearest millimetre.  
Refer to Serck Audco Valves for valves for low temperature and with ENP plugs.

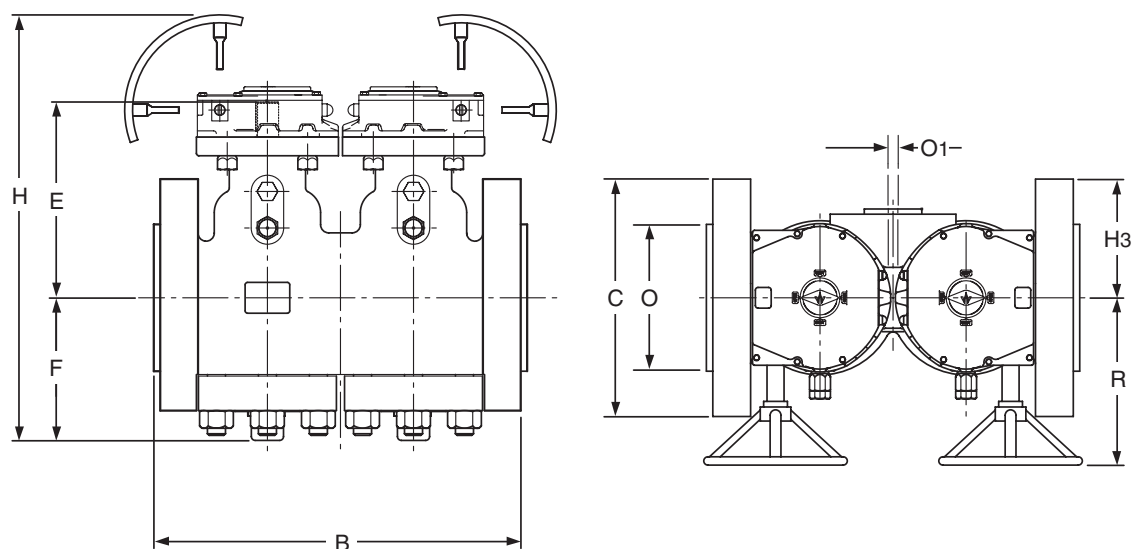

			50	80	100	150	200	250	300	350	400	450	500	600
B	Face-to-face RF	mm	292	356	432	559	660	788	838	889	991	1092	1194	1397
C	Flange Diameter	mm	152	191	229	279	343	407	483	534	597	635	699	813
	Flange Thickness (incl RF ht)	mm	31.8	38.2	44.5	54.0	62.0	70.0	73.0	76.3	82.6	89.0	95.3	108.0
	Handwheel Diameter	mm	--	--	--	400	400	500	500	400	400	500	500	500
E	CL to top of Stem	mm	193	242	287	300	349	380	437	446	532	549	591	703
F	CL to bottom of Body Cap	mm	128	164	179	210	273	308	340	355	415	455	490	543
H	Height	mm	--	--	--	485	787	899	940	915	1104	1205	1295	1438
O	RF Diameter	mm	92	127	157	216	270	324	381	413	470	533	584	692
T	CL to top of Handwheel	mm	--	--	--	695	514	591	600	560	689	750	805	895
R	CL to face of Handwheel	mm	--	--	--	314	391	332	391	414	500	529	529	543
O1	Bleed Size	mm	13	13	13	19	19	25	25	25	25	25	25	25
H3	CL to end of Bleed Flange Face	mm	90	95	105	130	175	185	205	229	247	277	337	300
	Weight (Approx)	kg	52	111	136	219	388	563	762	1113	1400	1866	2333	3417

-- Indicates not applicable, valves are wrench operated.

## Notes:

Dimension CL to top of Hand wheel 'T', CL to face of Hand wheel 'R' have been mentioned by assuming Pro-gear unit mounted on the Valve.

Weight mentioned are without considering Gear unit.

# TIPV - Class 300

Dimensions in these tables are for standard trim valves and are to the nearest millimetre.  
Refer to Serck Audco Valves for valves for low temperature and with ENP plugs.

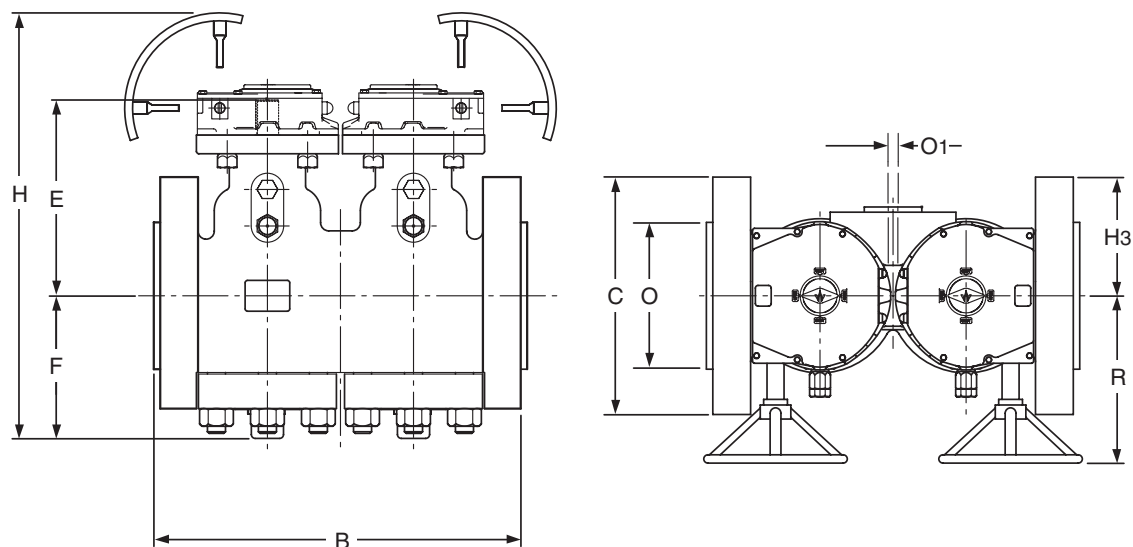

			50	80	100	150	200	250	300	350	400	450	500	600
B	Face-to-face RF	mm	292	356	432	559	660	788	838	889	991	1092	1194	1397
C	Flange Diameter	mm	165	210	254	318	381	445	521	584	648	712	775	914
	Flange Thickness (incl RF ht)	mm	31.8	38.2	44.5	54.0	62.0	70.0	73.0	76.3	82.6	89.0	95.3	108.0
	Handwheel Diameter	mm	--	--	--	500	400	500	500	400	500	500	500	500
E	CL to top of Stem	mm	193	242	287	300	349	380	437	446	532	549	591	703
F	CL to bottom of Body Cap	mm	128	164	179	210	273	308	340	355	415	455	490	543
H	Height	mm	--	--	--	744	787	904	940	965	1154	1205	1295	1438
O	RF Diameter	mm	92	127	157	216	270	324	381	413	470	533	584	692
T	CL to top of Handwheel	mm	--	--	--	534	514	596	600	610	739	750	805	895
R	CL to face of Handwheel	mm	--	--	--	329	391	406	391	429	515	529	529	543
O1	Bleed Size	mm	13	13	13	19	19	25	25	25	25	25	25	25
H3	CL to end of Bleed Flange Face	mm	90	95	105	130	175	185	205	229	247	277	337	350
	Weight (Approx)	kg	52	111	136	219	388	563	762	1113	1400	1866	2333	3417

-- Indicates not applicable, valves are wrench operated.

## Notes:

Dimension CL to top of Hand wheel 'T', CL to face of Hand wheel 'R' have been mentioned by assuming Pro-gear unit mounted on the Valve.

Weight mentioned are without considering Gear unit.

# TIPV - Class 600

Dimensions in these tables are for standard trim valves and are to the nearest millimetre.  
Refer to Serck Audco Valves for valves for low temperature and with ENP plugs.

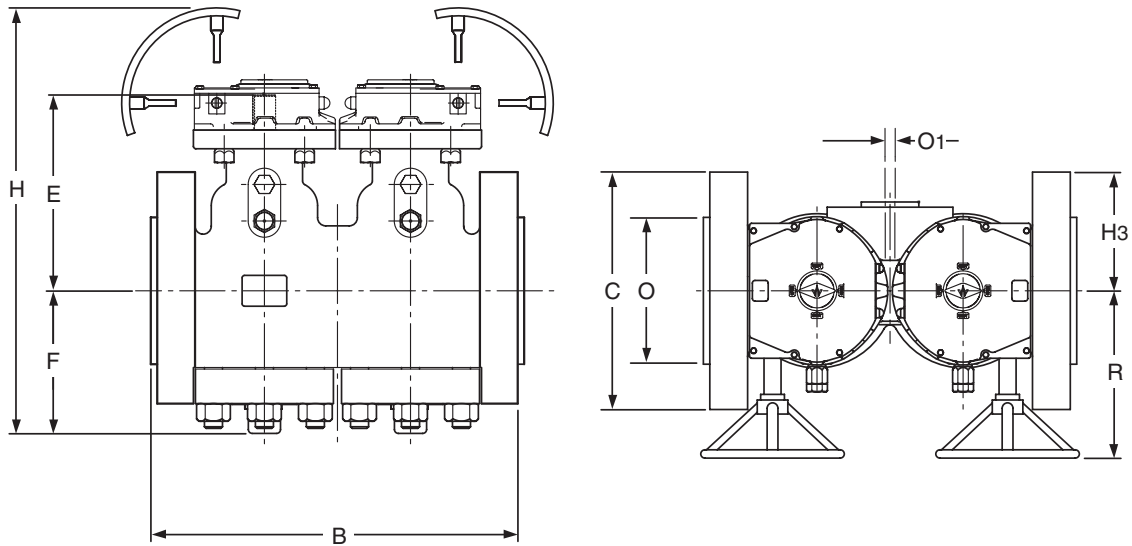

			50	80	100	150	200	250	300	350	400	450	500	600
B	Face-to-face RF	mm	292	356	432	559	660	788	838	889	991	1092	1194	1397
	Face-to-face RTJ	mm	295	359	435	562	663	791	841	892	994	1095	1200	1407
C	Flange Diameter	mm	165	210	273	356	419	508	559	604	686	743	813	940
	Flange Thickness RF (incl RF ht)	mm	31.8	38.2	44.5	54.0	62.0	70.0	73.0	76.3	82.6	89.0	95.3	108.0
	Flange Thickness RTJ (incl RTJ ht)	mm	33.3	39.7	46.0	55.5	63.5	71.5	74.5	77.8	84.0	90.5	98.4	112.7
	Handwheel Diameter	mm	--	--	400	400	500	500	400	500	500	500	500	500
E	CL to top of Stem	mm	193	242	287	300	349	380	437	446	532	549	591	703
F	CL to bottom of Body Cap	mm	128	164	179	210	273	308	340	355	415	455	490	543
H	Height	mm	--	--	640	698	837	904	940	1025	1145	1205	1295	1438
O	RF Diameter	mm	92	127	157	216	270	324	381	413	470	533	584	692
	RTJ Diameter	mm	108	146	175	241	302	356	413	457	508	575	635	749
T	CL to top of Handwheel	mm	--	--	461	488	564	596	600	670	730	750	805	895
R	CL to face of Handwheel	mm	--	--	299	429	406	453	438	529	484	529	529	543
O1	Bleed Size	mm	13	13	13	19	19	25	25	25	25	25	25	25
H3	CL to end of Bleed Flange Face	mm	90	95	105	130	175	185	205	229	247	277	337	350
	Weight (Approx)	kg	52	111	136	219	388	563	762	1113	1400	1866	2333	3417

-- Indicates not applicable, valves are wrench operated.

## Notes:

Dimension CL to top of Hand wheel 'T', CL to face of Hand wheel 'R' have been mentioned by assuming Pro-gear unit mounted on the Valve.

Weight mentioned are without considering Gear unit.

# TIPV - Class 900

Dimensions in these tables are for standard trim valves and are to the nearest millimetre.  
Refer to Serck Audco Valves for valves for low temperature and with ENP plugs.

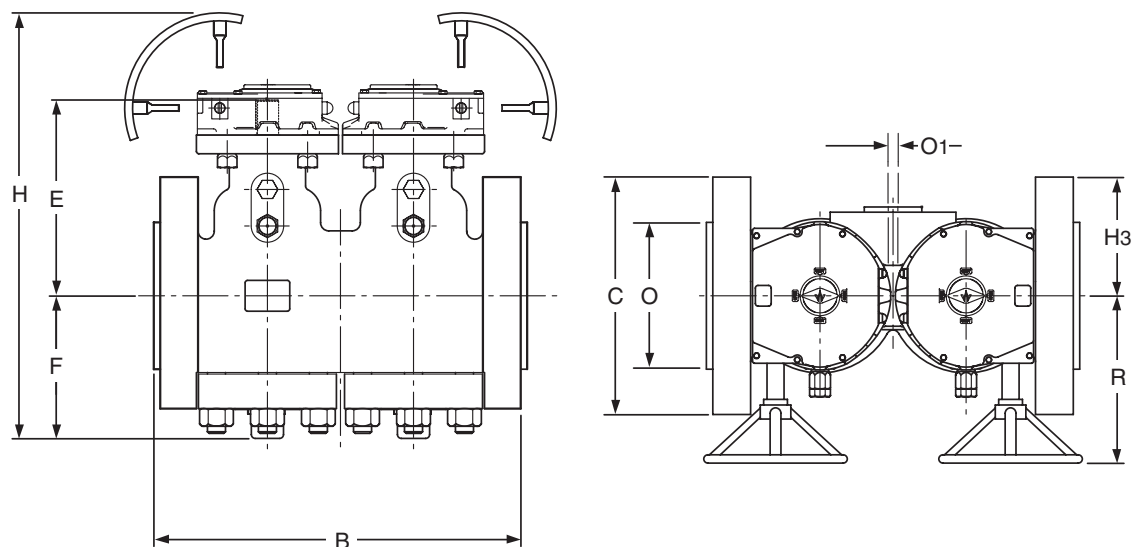

		50	80	100	150	200	250	300	350	400	450	500	600	
B	Face-to-face RF	mm	369	381	457	610	737	838	965	1029	1130	1219	1321	1549
	Face-to-face RTJ	mm	372	384	460	613	740	841	968	1039	1140	1232	1334	1568
C	Flange Diameter	mm	216	242	293	381	470	546	610	642	705	787	857	1042
	Flange Thickness RF (incl RF ht)	mm	44.5	44.5	51.0	62.0	70.0	76.2	85.8	92.2	95.3	108.0	114.4	146.0
	Flange Thickness RTJ (incl RTJ ht)	mm	46.0	46.0	52.5	63.5	71.5	77.7	87.3	96.8	100.0	114.3	120.7	155.6
	Handwheel Diameter	mm	300	400	400	500	600	500	500	500	400	500	500	600
E	CL to top of Stem	mm	203	244	280	334	372	436	481	494	554	635	638	763
F	CL to bottom of Body Cap	mm	124	164	176	240	285	330	370	407	484	484	540	611
H	Height	mm	457	602	618	788	1201	967	1058	1112	1208	1315	1341	1604
O	RF Diameter	mm	92	127	157	216	270	324	381	413	470	533	584	692
	RTJ Diameter	mm	124	155	181	241	419	362	419	467	524	594	648	772
T	CL to top of Handwheel	mm	333	438	442	548	632	637	688	705	724	830	830	993
R	CL to face of Handwheel	mm	253	314	314	397	426	475	529	529	528	543	543	563
O1	Bleed Size	mm	13	13	13	19	19	25	25	25	25	25	25	25
H3	CL to end of Bleed Flange Face	mm	103	95	102	130	190	273	261	261	310	340	360	370
	Weight (Approx)	kg	68	120	145	320	530	880	1400	1450	2325	3155	3520	●

● Refer to Serck Audco Valves for details.

## Notes:

Dimension CL to top of Hand wheel 'T', CL to face of Hand wheel 'R' have been mentioned by assuming Pro-gear unit mounted on the Valve.

Weight mentioned are without considering Gear unit.

# TIPV - Class 1500

Dimensions in these tables are for standard trim valves and are to the nearest millimetre.  
Refer to Serck Audco Valves for valves for low temperature and with ENP plugs.

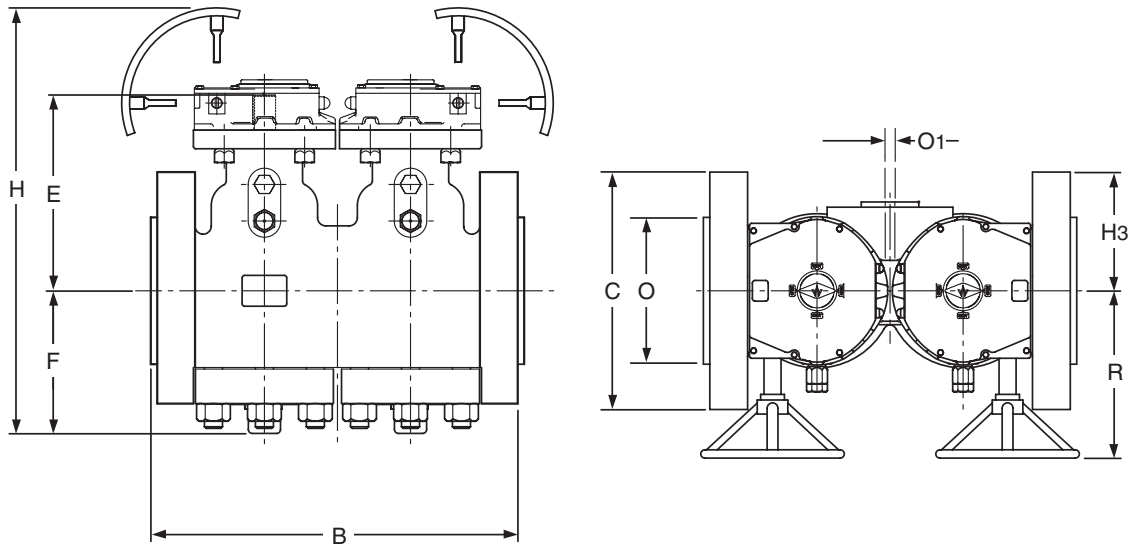

			50	80	100	150	200	250	300	350	400	450	500	600
B	Face-to-face RF	mm	369	470	546	705	832	991	1130	1257	1384	1537	1664	1943
	Face-to-face RTJ	mm	372	473	549	711	841	1000	1146	1276	1407	1559	1686	1971
C	Flange Diameter	mm	216	267	312	394	483	584	673	750	826	914	984	1169
	Flange Thickness RF (incl RF ht)	mm	45	54	60	89	99	115	131	140	153	169	184	210
	Flange Thickness RTJ (incl RTJ ht)	mm	46	56	62	92	103	119	135	144	164	180	196	224
	Handwheel Diameter	mm	300	500	400	400	400	400	400	500	500	500	600	●
E	CL to top of Stem	mm	203	244	276	334	382	434	502	482	622	636	740	●
F	CL to bottom of Body Cap	mm	124	179	195	251	300	350	388	408	495	545	567	●
H	Height	mm	457	667	648	751	842	933	1044	1090	1305	1405	1516	●
O	RF Diameter	mm	92	127	157	216	270	324	381	413	470	533	584	692
	RTJ Diameter	mm	124	168	194	248	318	372	438	489	546	613	673	794
T	CL to top of Handwheel	mm	333	488	453	500	542	583	656	682	810	860	949	●
R	CL to face of Handwheel	mm	253	329	314	391	437	514	514	484	552	529	563	●
O1	Bleed Size	mm	13	13	13	19	19	25	25	25	25	25	25	25
H3	CL to end of Bleed Flange Face	mm	103	134	110	160	186	300	295	295	333	377	466	●
	Weight (Approx)	kg	68	130	195	435	722	1241	1965	2250	3188	3700	5987	●

● Refer to Serck Audco Valves for details.

## Notes:

Dimensions for sizes not developed are left with blanks.

Dimension CL to top of Hand wheel 'T', CL to face of Hand wheel 'R' have been mentioned by assuming Pro-gear unit mounted on the Valve.

Weight mentioned are without considering Gear unit.

# TIPV - Class 2500

Dimensions in these tables are for standard trim valves and are to the nearest millimetre.  
Refer to Serck Audco Valves for valves for low temperature and with ENP plugs.

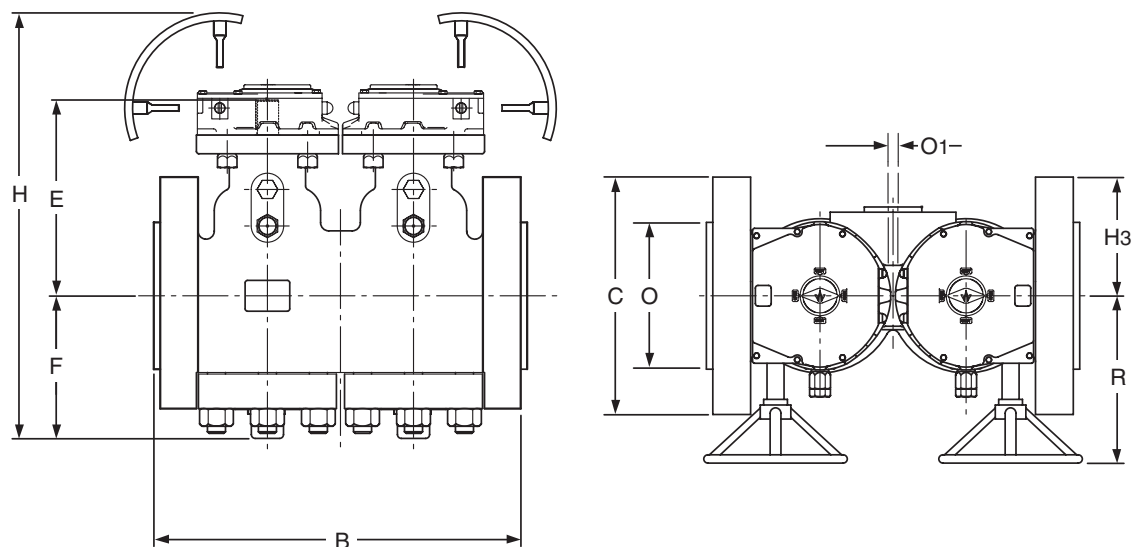

			50	80	100	150	200	250	300
B	Face-to-face RF	mm	451	578	673	914	1022	1270	1422
	Face-to-face RTJ	mm	454	584	683	927	1038	1292	1444
C	Flange Diameter	mm	235	305	356	483	553	673	762
	Flange Thickness RF (incl RF ht)	mm	57.2	73.0	82.6	114.4	133.4	171.5	190.0
	Flange Thickness RTJ (incl RTJ ht)	mm	58.7	76.2	87.3	120.6	141.2	182.6	201.0
	Handwheel Diameter	mm	300	400	300	400	600	400	500
E	CL to top of Stem	mm	264	291	311	372	387	474	532
F	CL to bottom of Body Cap	mm	162	252	253	312	340	402	478
H	Height	mm	554	719	682	837	1010	1027	1202
O	RF Diameter	mm	92	127	157	216	270	324	381
	RTJ Diameter	mm	133	168	203	279	340	425	495
T	CL to top of Handwheel	mm	392	467	429	525	670	625	724
R	CL to face of Handwheel	mm	308	429	414	438	495	514	538
O1	Bleed Size	mm	13	13	13	19	19	25	25
H3	CL to end of Bleed Flange Face	mm	92	187	180	188	290	265	305
	Weight (Approx)	kg	107	230	370	825	1290	2235	3380

## Notes:

Dimension CL to top of Hand wheel 'T', CL to face of Hand wheel 'R' have been mentioned by assuming Pro-gear unit mounted on the Valve.

Weight mentioned are without considering Gear unit.

# Materials

## Body Materials

	SAV Specification	Used for	Comparable Specifications	Form
<b>CARBON STEEL</b>	ASTM A216 Gr. WCB & WCC, Max. C 0.25%, Max. hardness Rc. 22	Bodies all types	BS 1504-161 Grade 480	CASTING

Alternative materials available include:

ASTM A216 Gr. WCB and BG/GBE/C9 (British Gas Corporation specification - casting)

ASTM A352 Gr. LCB (carbon steel low temperature - casting)

ASTM A352 Gr. LCC maximum carbon content 0.23% (carbon manganese steel low temperature - casting)

ASTM A350 Gr. LF2 (carbon manganese steel low temperature - forging)

API 6A used for bodies to API 6A

ASTM A217 Gr. WC1/WC6 (carbon/alloy steel - casting)

ASTM A351 Gr. CF8M/CF8/CF3M (stainless steel - casting)

Duplex stainless steels

For other material options please contact Serck Audco Valves.

## Plug Materials

	SAV Specification	Used for	Comparable Specifications	Form
<b>CARBON STEEL</b>	ASTM A105 or ASTM A216 Gr. WCB	Case Hardened/NACE all sizes electroless nickel 0.003"	BS 1503-164-490 BS 1504-161 Grade 480	FORGING/ CASTING
	BS 970 Gr. 070 M20	Bodies all types	BS 1504-161 Grade 480	WROUGHT BAR

Alternative materials available include:

ASTM A352 Gr. LCB (carbon steel low temperature)

ASTM A352 Gr. LCC maximum carbon content 0.23% (carbon manganese steel low temperature)

ASTM A350 Gr. LF2 (carbon manganese steel low temperature)

ASTM A351 Gr. CF8M (18/10/2 austenitic stainless steel)

ASTM A747 Gr. CB7 CU1 (17-4 PH stainless steel)

ASTM A705 Type 630 (17-4 PH stainless steel)

ASTM A564 Type 630 (17-4 PH stainless steel)

Duplex stainless steels

For other material options please contact Serck Audco Valves.

## Stem Materials

	SAV Specification	Used for	Comparable Specifications
<b>ALLOY STEEL</b>	BS 970 Gr. 709M40 (1% Cr. 1/2% Mo) Max. Hardness Rc. 22	All classes	AISI 4140
<b>STAINLESS STEEL</b>	ASTM A705/564 Type 630 17-4 PH	Corrosive services or low temperatures	-

Alternative material available:

BS 3076 NA18 (K500 Monel) - Nickel Copper Aluminium Alloy

For other material options please contact Serck Audco Valves.

# Materials

## Cover Materials

	SAV Specification	Used for	Comparable Specifications	Form
CARBON STEEL	ASTM A105	2" - 4"	BS 1503-164-490	FORGING
	ASTM A516 Gr. 70 Max. Hardness Rc. 22	6" and above All Classes	BS 1501-151 Grade 430	PLATE
ALLOY STEEL	BS 970 Gr. 709 M40	Some large valves	AISI 4140	FORGING

Alternative materials available:

ASTM 516 Gr. 70 Charpy Tested

BS 1501 Gr. 316 S11/13 (stainless steel) - Comparable to ASTM A240 Gr. 316

Duplex stainless steels

For other material options please contact Serck Audco Valves.

## Bolting Materials

	SAV Specification	Used for	NACE Specifications
ALLOY STEEL STUDS	ASTM A193 Gr. B7	All Classes	ASTM A193 Gr. B7M
CARBON STEEL NUTS	ASTM A194 Gr. 2H	All Classes	ASTM A194 Gr. 2HM

Alternative materials available:

ASTM A193 Gr. B7M

ASTM A194 Gr. 2HM

ASTM A320 Gr. L7M

ASTM A320 Gr. L7 (low temperature) - STUDS

ASTM A194 Gr. L4 (L7/S4 supplement, low temperature) - NUTS

BS 3076 NA18 (K Monel) - Nickel Copper Aluminium Alloy - STUDS

BS 3076 NA13 (400 Monel) - Nickel Copper Alloy - NUTS

For other material options please contact Serck Audco Valves.

# Sealants (methods of injection)

Audco sealants are formulated specially for use in Audco valves and no other types of sealant should be used, nor should Audco valve sealants be used for any purpose other than injecting into valves without our express recommendation.

## Injection by Sealant Gun

All valves are fitted with a taper threaded sealant injector positioned in the centre of the stem or as a side feed in the body.

## Sealant Guns

Sealant guns are fitted with flexible hoses giving a hook-on connection to the combination sealant injector on the valve.



**Type CL 400-D**

Hand operated hydraulic gun, fitted with a pressure gauge. This gun is designed to take Size 'K' sealant sticks. Effortless to operate and gives positive indication of when valve has been fully charged.

Further information available on request.



**Hypregun**

Easy to use pneumatically operated sealant injection gun. Uses bulk lubricant in 5 quart cans. Recommended for large valve installations such as manifolds, gas processing plants, compressor stations, refineries and water treatment plants.

## Pneumatic Sealant Injection Equipment

For compressed air actuated valves a pneumatic dispenser can be supplied.

It has a 3lbs capacity sealant reservoir and a pumping element suitable for use on valves operating at line pressures up to 5000 lb/in<sup>2</sup>. A predetermined quantity of sealant is fed into the valve at each operation. Further information available on request.

# Sealants (multi-purpose and specialised)

## Multi-Purpose Sealants

In recent years the Serck Audco Valves research laboratories have paid great attention to the development of multi-purpose sealants to simplify plant maintenance where many services are encountered. As a result of this research, we are able to offer two sealants which, between them, cover a very wide variety of services and have replaced many of the older Audco sealants. A single multi-purpose sealant can often be used throughout an entire plant, even though that plant handles a variety of fluids. This simplifies maintenance and reduces the number of sealants which need to be stocked.

## Lubricating and Sealing Properties

In addition to being suitable for a wide range of services, these sealants have excellent lubricating properties and great film strength. They supplement Super LoMu treatment to reduce friction between the seating surfaces and provide a very effective seal at higher line pressures.

## Suitability Tests

The table below summarises our general sealant recommendations. Further details for specific services are contained in the Chemical Resistance Section of our catalogue.

Where there is any doubt as to the suitability of a particular sealant for a given service, tests should be carried out in a new clean valve. Experience shows that this is the only satisfactory way to conduct such tests. Laboratory tests carried out by immersing a stick of sealant in a breaker of the line fluid have proved most misleading. Where samples of fluids can be supplied, together with details of temperatures and pressure rating involved, we can carry out tests in our own laboratories and give recommendations based upon the results.

## Temperature Range

The temperature range of each sealant is given in these tables but the sealant performance within the given temperature range may vary with the particular fluid being handled.

## Multi-Purpose Sealants

Sealant	Form	Colour	Temperature Range* Min. Max.	Recommended for	Do not use on
731	Sticks (all sizes) Cartridges Bulk	Cream	-15°C 230°C -20°C 230°C -25°C 230°C	Most chemical plant services, water, aqueous solutions, dilute acids, all alkaline solutions, com- pressed air, tars, bitumens.	Strong acid solutions, petroleum products.
733	Sticks (all sizes) Cartridges Bulk	Cream	0°C 250°C -10°C 250°C -15°C 250°C	Most hydrocarbons, butane, propane, gasoline, kerosene, oils, fuel oils. Natural gas, manufactured gas (including gas with carbon dioxide, hydrogen sulphide, water and condensate), LPG, glycols.	Strong alkalis, high aromatic solvents.

\* Temperature range is dependent upon nature of service.

# Sealants (multi-purpose and specialised)

## Specialised Sealants

Sealant	Form	Colour	Temp Range °C ( °F)		Recommended for	Do not use on
			Min	Max		
201	H & K Sticks Cartridges Bulk	White	-7 (-20)	200 (390)	Domestic water services, foodstuffs and pharmaceuticals.	As 731.
147	H & K Sticks Cartridges Bulk	White	-10 (14)	70 (160)	Nitrating acids, sulphuric acid and other oxidising elements.	Hydrocarbon chlorinated and aromatic solvents.
563	H & K Sticks Cartridges Bulk	Yellow	-10 (14)	150 (300)	Chlorinated and aromatic hydrocarbon solvents.	Strong acids, nitrating acids, water and water based services and alcohols.
734	H & K Sticks Cartridges Bulk	Cream	0 (32)	170 (340)	Water, high pressure, hot water and steam.	As 731.
735	H & K Sticks Hard grade Bulk only	Black	-40 (-40)	325 (620)	Hot gases and high temperature services 220°C maximum in the presence of oxygen.	Neat petroleum products. Strong mineral acids. Chlorinated and aromatic acids.
591	H & K Sticks Cartridges Bulk	Cream	0 (32)	300 (570)	Petroleum based heat transfer oils. Hot fuel oil to 120°C.	As 733.
608	H & K Sticks Cartridges Bulk	Off White	0 (32)	340 (650)	Hot hydrocarbon gases and vapours including high temperature cracking and reforming. Strong acids and alkalis to 150°C.	Aromatic and chlorinated solvents. Liquid hydrocarbons and nitrating acids.
574	Cartridges Soft grade Bulk only	Beige	-50 (-58)	50 (120)	Ammonia and brine.	As 731.
985	K Sticks Cartridges Soft grade Bulk only	Light Brown	-10 (12)	150 (300)	Sweet and sour natural and manufactured gas with water/organic condensates. Preferred at elevated temperatures.	As 733.
2977	K Sticks Cartridges Soft grade Bulk only	Black	-40 (-40)	325 (620)	As for 735, also oil and water mixtures where water content is above 50% in the mixture.	As 735.

# Sealants (packaging, storage and handling)

## Packaging of Stick Sealants

Sealant is supplied in sticks of suitable diameter and length, packed either singly or in boxes, as given in the following table. Weights will vary from those shown over a range of approximately 20 - 30% according to grade sealant.

Stick Sizes	H	K
Stick diameter (mm)	35	35
Stick length (mm)	150	240
Number of sticks in box	1*	1*
Weight of box (gms)	Single - 170 Box of 12 - 2270	Single - 230 Box of 12 - 2760

\*Note: Size 'H' and 'K' sticks are packed singly in cylindrical containers or in boxes of 12.

### Gun Sealants

Type ALG4 - Pre-packed cartridge of soft grade sealant.

Type 400-D - 'K' Stick.

Type ALG 3 - 'H' Stick

Sealant can be purchased in bulk in larger containers. Bulk supplies available are:

Type of Container	Can	Can	Pail	Drum	Drum
Net Weight	3 kg	5 kg	18 kg	80 kg	180 kg

## Packaging of Soft Grade Sealants

Soft grade sealants cannot be formed into sticks for screw application.

Most sealants are available in cartridges for direct insertion into Sealant Gun Type ALG4.

Bulk supplies of soft grade sealants are available in the same size containers as given in the table at the top of this page for bulk stick grade sealants. When soft grade sealants are required they should be ordered as such, e.g. 731 Soft Grade.

## Audco Stem Packing Compound

This is a material prepared in stick form for packing the stems of Type 'H' and Super 'H' valves. Stem packing must under no circumstances be used in the valve sealant system. Also, valve sealants are not suitable for sealing stems. Stem packing compound is supplied in cylindrical containers as follows:

Stick Size	A	B	D
Number of Sticks in Container	40	24	24

## Storage and Handling of Sealants

Sealants should be stored in clean, dry conditions away from heat and flame and strong oxidising agents. Keep containers closed and store sealants in their original containers until required for use.

All of our sealants have flash points above 150°C but some will burn if subjected to sufficiently fierce flames. If any sealant is incinerated avoid breathing the fumes.

Normal hygiene procedures should be followed e.g. avoid prolonged skin contact, wash hands thoroughly after use, etc.

Specific data sheets for each sealant are available on request.

## Serck Audco - setting the pace in valve technology

Serck Audco has a reputation for quality and reliability. This long established reputation is maintained by modern design and manufacturing techniques.

Today, the company, a member of the Flowserve Flow Control group, is one of the world's leading manufacturers and suppliers of valves and valve technology.

Serck Audco products are supplied and serviced around the globe, in industries as diverse as oil and gas, food and chemical processing.

Other products available:

- Double isolation plug valves
- Steel Super H plug valves
- Three way plug valves
- Jacketed plug valves
- Steel standard type plug valves
- Cast iron plug valves



**FLOWERVE INDIA CONTROLS PVT LTD-MMN PLANT**  
B-8, MMDA Industrial Area, Maraimalai Nagar,  
Kanchipuram Dist - 603209, Tamilnadu, India  
Phone: +91 44 2745 2323 Fax: +91 44 2745 2327  
Email : [AudcoPlugindia@flowserve.com](mailto:AudcoPlugindia@flowserve.com)  
[AudcoSlimsealindia@flowserve.com](mailto:AudcoSlimsealindia@flowserve.com)

**FLOWERVE**<sup>®</sup>

Flow Control